



3TNV76-CSA3

Industrial Diesel Engine

Performance Data

Dimensions

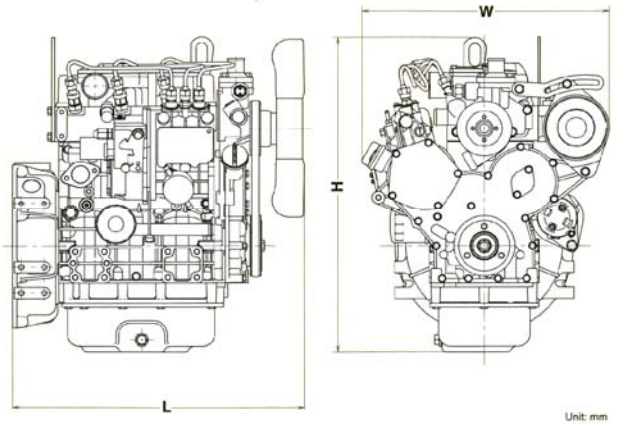
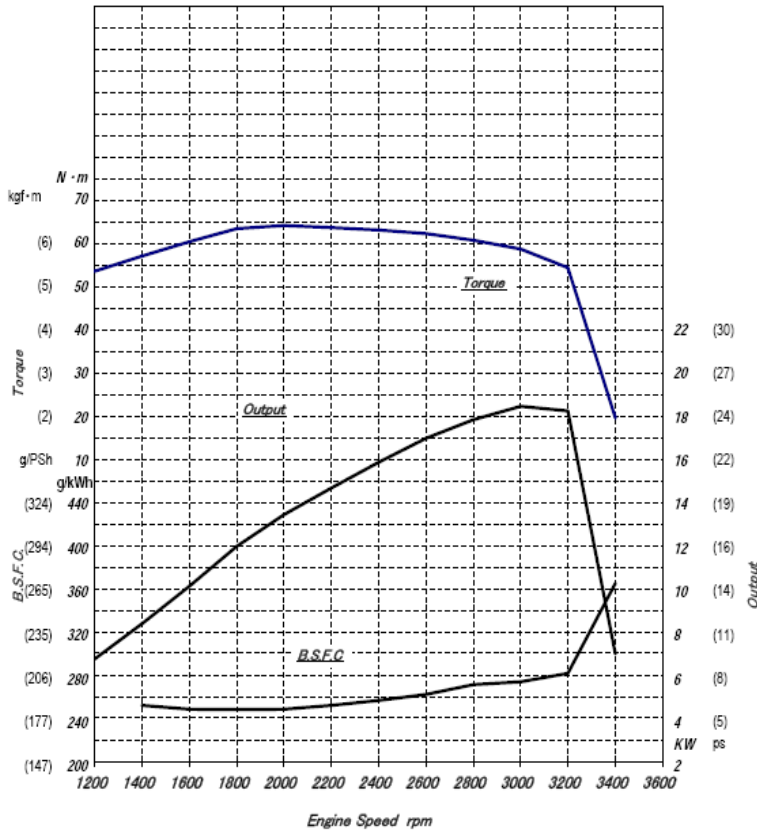

Length	21.4 in (543 mm)
Width	16.9 in (429 mm)
Height	22.6 in (574 mm)

Note: Dimensions depend on final specifications.

kW to Hp conversion used is expressed as: $HP = (kW \text{ value}) \times 1.34$

Rated Speed (rpm)	Net rated kW	Net rated HP	Max. Torque (ft-lb)
3200	18.6	25.1	49.1 @ 2300 rpm

Ratings Definitions and Conditions

*Rated power listed is NET engine output. The engine operating environment and driven machine conditions must be studied carefully when selecting an engine in order to ensure correct engine selection, maximize engine performance, extend engine service life and improve machine capacity.

Application standards for Yanmar industrial engines: Inlet air standard conditions with a total barometric pressure of 100kPa (29.5 in. Hg), with 30% relative humidity, and 25° C (77°F).

Consult the TNV Application Manual for additional engine ratings and engine application information.

Materials and specifications herein are intended to serve as a guide in engine selection and subject to change without notice. The International System of Units (SI) is used in this publication. Yanmar and its logos, as well as corporate identity used herein, are trademarks of Yanmar and may not be used without permission.